

City of Fairlawn Zoning, Housing & Residential Building Department

Deck Application

Project Address _____ Date _____
Property Owner _____ Phone _____
Property Owner Address (if different than above) _____
Contractor _____ Phone _____
Contractor Address _____

<u>Deck</u>	
Total Sq. Ft.	_____
Estimated Cost \$	_____
Posthole depth shall be 38" below grade	
Fee: \$25.00 Zoning + \$100.00 Building	
<u>Total: \$125.00</u>	

Submit two (2) sets of plans with this application and a plot plan. The undersigned (if not property owner) hereby states that authority has been granted by the owner to apply for this permit/license. This application is submitted for a permit/license to erect or alter a structure as described in this application, and the accompanying drawings, which are a part of this application. The acceptance of this /permit license herein applied for shall constitute an agreement on the part of the undersigned to abide by all the conditions herein contained. The undersigned shall comply with all rules and regulations of the City of Fairlawn, the adopted construction codes, and the laws of the State of Ohio, and this agreement, as a condition of said permit/license. Further, all work shall be conducted in a workmanlike manner, and all required inspections shall be called into the Building Department at least 24 hours in advance.

Non-Compliance: Projects begun prior to a zoning certificate or building permit being issued for a single family residential dwelling shall cost 150% of the applicable fee and for any structure other than a single family residential dwelling, shall cost 300% of the applicable fee. Work required by emergency repairs shall be exempt from this fee provided the permit is applied for within seventy-two hours of initiating the emergency repairs.

Please allow 7 – 10 days for processing of this application.

Applicant Signature _____ Date _____
Print Applicant Name _____ Phone _____
Email Address _____ Fax _____
(If you wish to be contacted by email)

3487 S. Smith Rd. · Fairlawn, OH 44333 · 330-668-9500 / (Fax) 330-668-9546
Email: bldg_zoning@fairlawn.us

Deck Plan Guide

Before you Apply:

- Visit <https://www.com.ohio.gov/dico/bbs/> to reference current State of Ohio residential building codes

Disclaimer: The information below is to be used as an informational guide and is not a comprehensive construction document. Depending on the design of your deck additional information may be required.

A. Completed Application Form

B. Provide a site plan

Your site plan should include the following:

- 1 Address
- 2 Property Lines
- 3 Label streets
- 4 Label backyard/front yard
- 5 Outline of your home and deck (with dimensions)
- 6 Distance from all property lines to deck

Tip: You may be able to obtain an aerial image from the Summit County Auditor's website.

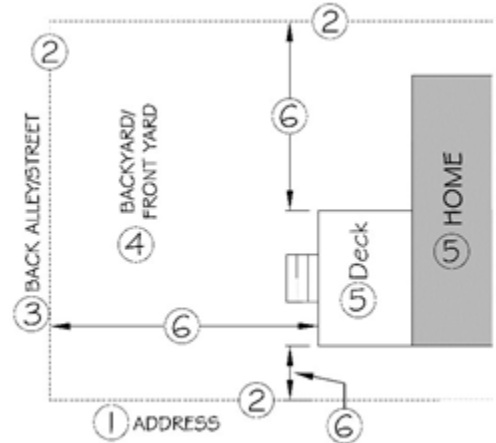

C. Provide a framing plan view

Your plan view should include the following:

- 1 Length and width of deck
- 2 Distance between posts
- 3 Size of cantilever
- 4 Length of joist span
- 5 Size and type of decking
- 6 Size of joist
- 7 Spacing between joists
- 8 Size of beam

Note: Identify framing connection/fastener connections including hangers, blocking, fasteners, etc.

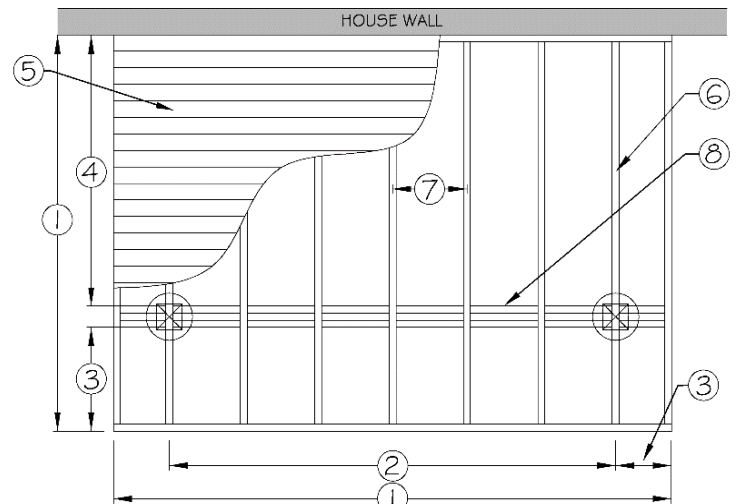

D. Provide a cross-section

Your cross section should include the following:

- 1 Footer depth
- 2 Footer material and dimensions
- 3 Post material and size
- 4 Deck floor to main floor distance
- 5 Ground to deck floor height (measured from lowest point)
- 6 Railing height
- 7 Railing opening size
- 8 Railing material

Note: If you are installing stairs, stair details including handrail details are required.

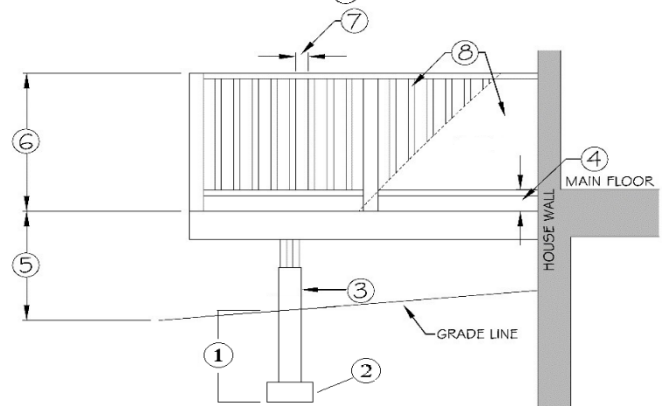

E. Provide details

- 1 Ledger board connection to house (fasteners, materials, flashing, etc.)
- 2 Handrail measurements, material, connections
- 3 Beam connection to post
- 4 Stair details (# risers, riser height, tread depth, handrail and guard height, etc.)

Note: Additional details or information may be required based on your design

